

(No Model.)

L. R. FAUGHT.
CLAMP FOR STATIONARY SPINDLES.

No. 257,157.

Patented May 2, 1882.

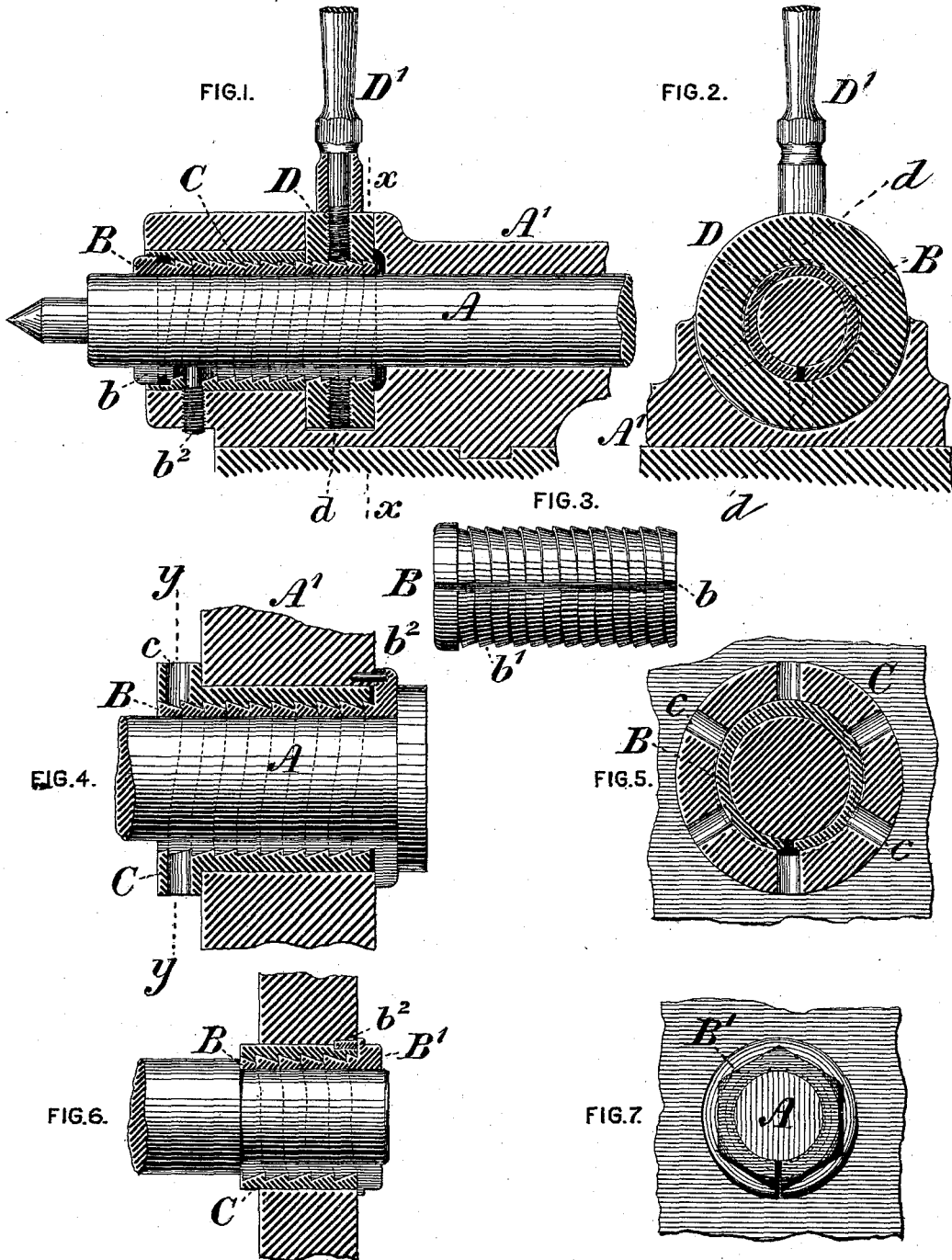

WITNESSES:

Geo. D. Collier
Geo. J. Kelly

INVENTOR

L. R. Faught,
by Collier & Bell,
attys.

UNITED STATES PATENT OFFICE.

LUTHER R. FAUGHT, OF PHILADELPHIA, PENNSYLVANIA.

CLAMP FOR STATIONARY SPINDLES.

SPECIFICATION forming part of Letters Patent No. 257,157, dated May 2, 1882.

Application filed March 31, 1882. (No model.)

To all whom it may concern:

Be it known that I, LUTHER R. FAUGHT, of the city and county of Philadelphia, in the State of Pennsylvania, have invented certain new and useful Improvements in Clamps for Stationary Spindles, of which improvements the following is a specification.

The object of my invention is to provide efficient and desirable means for locking a stationary spindle as against motion in its socket, and for readily and quickly releasing the same whenever required, in such manner that clamping action shall be exerted upon the spindle uniformly around its axis, the central position of the spindle in the socket be maintained, and wear of the parts be compensated for.

To these ends my improvements consist in the combination of a spindle, a flexible clamping-sleeve having a screw-thread of peculiar section formed upon its periphery, a socket or bushing having a corresponding internal thread, and means for changing the positions of the sleeve and socket relatively one to the other, as hereinafter more fully set forth.

In the accompanying drawings, Figure 1 is a longitudinal central section through a lathe-stock embodying my invention; Fig. 2, a transverse section through the same at the line xx of Fig. 1; Fig. 3, a view in elevation of the clamping-sleeve detached; Figs. 4 and 6, longitudinal central sections, showing modifications of my invention; Fig. 5, a transverse section at the line yy of Fig. 4; and Fig. 7, an end view, in elevation, of the construction shown in Fig. 6.

Referring to Figs. 1, 2, and 3, my improvements are shown as applied to the tail-spindle A of a lathe, which spindle is fitted in a bearing in the stock or socket A', so as to be susceptible of longitudinal movement therein, as from time to time required, by the ordinary devices. A clamping-sleeve, B, bored out centrally to fit easily on the spindle A, and split or divided longitudinally by a slot, b , so as to admit of lateral flexibility, surrounds the spindle A within the socket and adjacent to its end. A flattened screw-thread, b' , is formed upon the periphery of the clamping-sleeve B, said thread being of triangular section, with one of its sides substantially perpendicular to the sleeve and the other at an acute angle

therewith, the object of such construction being to admit of wedging action being exerted and easy release effected between said thread and a surrounding female thread of corresponding section, which is formed in a bushing, C, secured in the socket A', concentrically with the spindle A, such wedging and release being dependent respectively upon the direction in which changes of position of the sleeve relatively to the surrounding female thread tend to be made.

The bushing C may, if preferred, be dispensed with and the internal thread be formed directly in the socket A'. The operative relation of the parts will be the same in either case; but the construction shown may be found more desirable in point of convenience of construction and repairs. A circular nut, D, having a series of sockets, d , for the insertion of a handle, D', is fitted neatly in an opening in the socket A', adjacent to the inner end of the clamping-sleeve, and is provided with a female thread engaging the thread b' of the clamping-sleeve B. Rotary movement of the clamping-sleeve is prevented by a pin or stud, b^2 , passing through the socket A' and into the sleeve, and upon the movement of the handle D' and nut D in one or the other direction respectively the sleeve B will, through the engagement of its thread with that of the nut and socket, be either compressed tightly upon the spindle A, thereby holding the same in fixed position, or outwardly expanded, so as to release the spindle and admit of its free longitudinal movement, as desired. It will be observed that compressing action is exerted uniformly around and toward the axis of the spindle, and that therefore the latter is maintained truly in its adjusted axial position under all circumstances, whether the parts be new or worn, compensation for wear being provided for by such radial compression and by the provision for changing the position of the operating-handle from one to another of the sockets in the nut D.

Figs. 4 and 5 illustrate a modification of my invention as applied to the locking and releasing of a spindle, A, which may be either fixed or movable in its bearing in a frame or housing, A'. The clamping-sleeve B is similar in construction to that before described, having an analogous thread, b , and a longitudinal slot,

b' , on one side of its central bore, and its rotation in the housing is prevented by a pin, b^2 . Compression and expansion of the sleeve are effected by the movement in one or the other direction of a bushing, C, having an internal thread corresponding with the thread of the sleeve, and provided with a series of radial sockets, c , adjacent to one of its ends.

The modification shown in Figs. 6 and 7 differs from that last above described in the particular that the bushing C is fixed in the housing by the pin or key b^2 , and the application of power for clamping and releasing is made to a squared head, B', formed on one end of the clamping-sleeve, the compression and expansion of the latter being effected by the action of its thread upon that of the bushing, as in each of the instances before described.

I claim as my invention and desire to secure by Letters Patent—

1. The combination, substantially as set forth, of a spindle, a split or divided clamping-sleeve having a flattened screw-thread formed upon its periphery, a socket or bushing having an internal thread of corresponding section, and a head or nut, by which the sleeve and socket may be varied in position circumferentially relatively one to the other.

2. The combination, substantially as set forth, of a spindle, a clamping-sleeve and socket, each threaded as described, a pin or stop which prevents rotation of the sleeve in the socket, and a nut fitting a recess in the socket and having an internal thread engaging the thread of the clamping-sleeve.

L. R. FAUGHT.

Witnesses:

J. SNOWDEN BELL,
WALTER S. GIBSON.